

14. Aim your SS3 pods on each side, so that the top of the beam pattern is on the cutoff line mark.

15. Tighten the 5/32" allen bolts back down. Do not overtighten or use power tools to torque them down.

16. Secure the fender liner to the bumper using the original hardware to complete installation. (This step wasn't included, but should it be?)

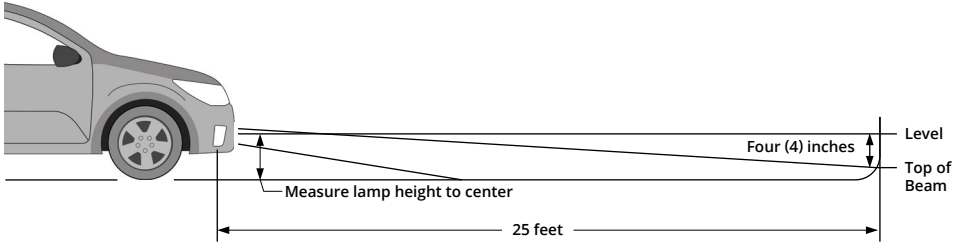

Please contact **Diode Dynamics** should you have any questions about the installation or wiring process, at **314-205-3033** (10a-5p CST) or [contact@diodedynamics.com](mailto:contact@diodedynamics.com).

**NEED MORE HELP?**

Scan the QR code to link to our YouTube Channel!

We continuously bring in vehicles to our testing garage in order to create step-by-step videos to walk you through the installation process on your specific vehicle. Scan the QR code to see all our installation videos. Be sure to subscribe to our channel to stay up-to-date on the newest products and videos from Diode Dynamics!

YouTube



**This installation guide is for the following SKUs:**

- DD6545** Worklight SS3 Sport Type X Kit White SAE Driving
- DD6546** Worklight SS3 Sport Type X Kit White SAE Fog
- DD6547** Worklight SS3 Sport Type X Kit Yellow SAE Fog
- DD6548** Worklight SS3 Pro Type X Kit White SAE Driving

- DD6549** Worklight SS3 Pro Type X Kit White SAE Fog
- DD6550** Worklight SS3 Pro Type X Kit Yellow SAE Fog
- DD6704** Worklight SS3 Max Type X Kit White SAE Fog
- DD6705** Worklight SS3 Max Type X Kit Yellow SAE Fog

**100% SATISFACTION**  
**GUARANTEE**



Thank you for your purchase of our new SS3 Type X Foglight Kit. CAD-designed to use existing mounting points, this kit is compatible with the 2011-2014 Subaru WRX and 2008-2009 Subaru Legacy. Installation instructions are included below.

**Please contact us if you have any questions.**

COMPUTER DESIGNED  
**OEM FITMENT**

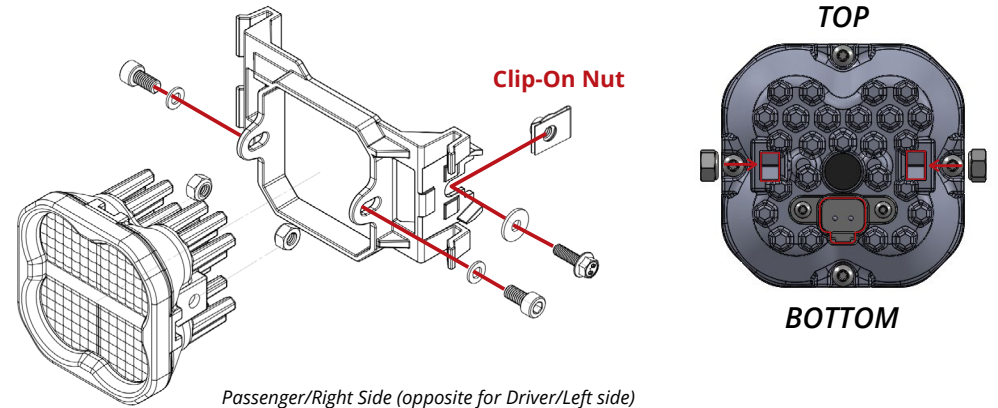

1. Install the supplied clip-on nut onto the bracket, with the threads facing toward the SS3 pod. Then install the supplied nuts into the pod housing with the nylon facing inward.

2. Attach the bracket to the pod using the supplied screws and washers. See diagram above. Ensure that the screws are tightened such that the pod retains its position, but can pivot with force for aiming.

*See inside for further instructions.*



3. Remove the two push clips securing the fender liner to the bottom of the bumper.

4. Remove the 10mm bolt securing the fender liner to the bottom of the bumper.



5. Pull the fender liner back and remove the two 10mm bolts holding the factory fog lamp in place. Remove the factory lamp.



6. Install the SS3 pod and bezel onto the vehicle using the included 8mm hex bolt.

7. Plug the SS3 into the factory fog light harness using the included DT wire adapter. Test function. If the light does not turn on, try flipping the connector 180°.

8. Repeat the steps on the other side of the vehicle.

### Aiming Instructions



9. Park your vehicle 25 feet away from a wall or garage door on a level surface.



10. Loosen the 5/32" allen bolts on each side of your SS3 pod, just enough to allow you to adjust the pod.



11. On your vehicle, measure the distance between the ground and the center of your SS3 pod. This is your mounting height.

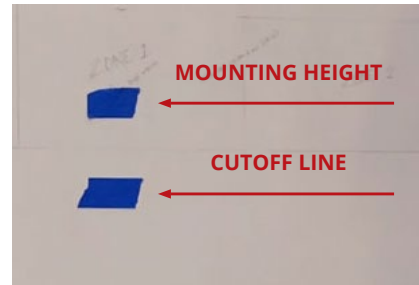

12. Mark the mounting height on the wall or garage door using tape.

13. Add another piece of tape four inches below the mounting height. This is your fog light cutoff line.

*See back for further instructions.*