



Installation Instructions

MasterTop® SkyMaster Fastback Complete Soft Top for 2007-2018 Jeep JKU Wrangler

Item #155014XX



Parts List:

Top deck/header assembly- Qty 1
Driver side quarter window- Qty 1
Passenger side quarter window- Qty 1
Rear window-Qty1
Rear bow assembly-Qty 1
Center bow assembly-Qty 1
Driver's side door surround-Qty 1
Passenger side door surround- Qty 1
Door surround knobs- Qty 6
Rear strap assemblies-Qty2
Over door bow quick release- Qty 2
Tailgate Bar- Qty 1
Tailgate Bar Clips- Qty 2

Required Tools:

Safety glasses
Phillips screw driver
Flat head screw driver
Socket wrench
13mm socket
Pliers

Loss of vehicle control involves risk of death or serious injury, particularly to parts of your body not restrained within vehicle. This product is intended for weather protection only and should not be relied upon to contain occupants in the event of an accident or to protect from either ground contact or falling objects. To reduce risk of accident or injury:

- ALWAYS WEAR SEATBELTS
- Always keep head, arms & body parts within vehicle.
- Fully secure or stow the soft top before driving according to instructions. Never try to latch or fold soft top while driving. Do not use if damaged or worn.
- Read and follow all instructions & warnings accompanying this product, in your vehicle owner's manual and Off Road Driving Supplement.

WARNING

CAUTION

RISK OF EYE INJURY. Safety glasses should be worn at all times while installing or maintaining this product.



Important Safety information

Your MasterTop® soft top is intended to increase the utility and enjoyment of your offroad capable vehicle. Before installation, please take a moment to review the following safety information and installation instructions. Important safety information is generally preceded by one of three signal words indicating the relative risk of injury.

The signal words mean:

WARNING A hazardous situation which, if not avoided, could result in death or serious injury. You **CAN** be **KILLED** or **SERIOUSLY HURT** if you don't follow instructions.

CAUTION A hazardous situation which, if not avoided, could result in minor or moderate injury. You **CAN** be moderately **HURT** and also may suffer property damage if you don't follow instructions.

NOTICE Careful attention is required to this instruction or operation but does generally not relate to personal injury. Damage to your MasterTop product or other property may result if you don't follow instructions.

Before you begin Installation:

Congratulations on your purchase of the MasterTop Fastback Top! This high quality soft top is designed to provide years of protection from whatever nature can throw at you! We have used only the finest materials in creating this soft top but like any product that is exposed to the elements, there is some general maintenance that is required to keep your Top looking like new. Please see page 9 for these important maintenance tips.

Thank you again for your purchase and let's start the installation process!

NOTICE

For a smooth fit and ease of installation, this top should be installed at temperatures above 72 degrees. Below this temperature, the fabric may contract an inch or more making it difficult to install. We highly recommend taking the top out of the package and letting it sit inside a warm place or direct sunlight for 1-2 hours before you install the top. When warm, this top will install quickly.

When unpacking, check to make sure all parts are included.

If any part is missing or broken, please call MasterTop customer service at 720-575-5440.

Step 1: Door Surround Assembly:

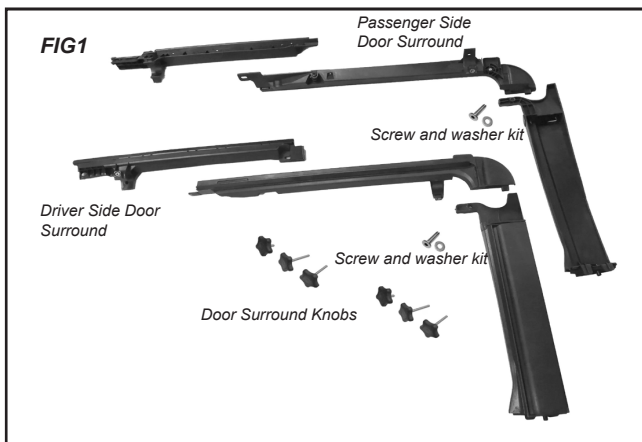

Put on safety glasses. Carefully remove all the contents of the large shipping box onto a table top or onto the ground on top of a soft towel.

Once the components are removed from the shipping box, locate the front and rear door surround components and knobs (FIG1)

Carefully remove the contents of each box organizing them as shown in Fig.1 making sure the passenger side and driver's side components are separated.



Step 2: Rear Over Door Surround Assembly

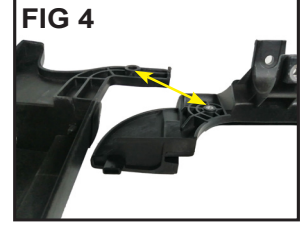
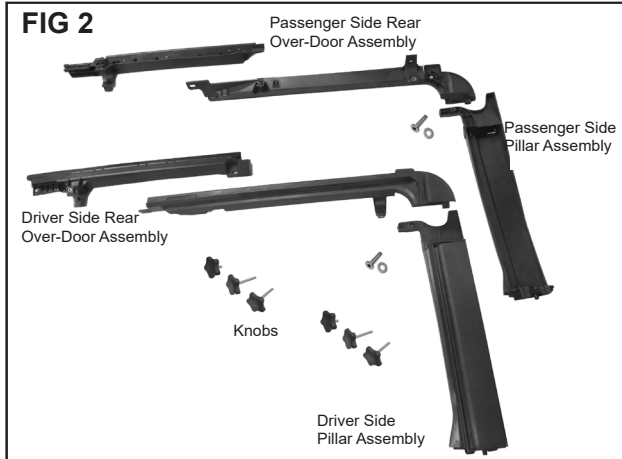

Locate the driver's side rear over door assembly and the driver's side Pillar assembly shown in FIG2

In the Driver's side Rear over door assembly, there is a screw and washer installed for shipping (Fig 3). Remove this screw and washer using the included 4mm Allen head tool and set aside (Do not lose this screw/washer). Line up the Driver's side Rear over door assembly and the driver's side Pillar assembly as shown in Fig 4 making sure the holes line up. Place the washer over the top of the hole as shown in Fig 6 and insert the screw (Fig 7). Tighten this screw securing the two pieces (Fig 7a).

Repeat the above assembly on the Passenger side Rear over door and pillar assemblies.

Step 3: Install Rear Door Surrounds to Jeep



Locate the assembled Driver's side rear door surround (Fig 8).

On the bottom of the vertical pillar portion of the assembled door surround is a pin that will be inserted into the body tub as shown in FIG9.

On the body tub you may have a rubber seal that is called out in FIG 10. This seal will remain on the body tub. Insert the door surround pin into the body tub as shown in FIG 11 (With the rubber seal still on the vehicle).

After inserting the pin, locate the upper portion of the door surround "C" attachment and push onto roll bar (Figs 12 & 13).

The "C" should fit in the cutout of the roll bar pad. Line up the threads in the "C" with the top hole in the roll bar.

Repeat this procedure on the passenger side.



Step 4: Secure Front & Rear Door Surrounds to Roll Bar



Locate the two sets of screw knobs. There should be (2) sets of three knobs with two the same length and one shorter length. The shorter knob attaches to the center hole on the door surrounds and the (2) longer knobs go on the front and rear holes.

Line up the door surround "C" attachment holes with the vertical holes in the roll bar. Slip the front long knob through the hole in the front door surround (FIG14). Tighten the knob securing the front door surround.

Repeat this procedure on the back of the rear door surround.

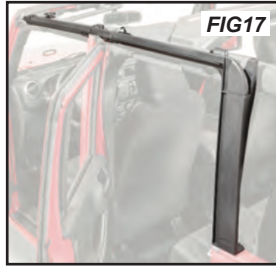

Finally, with the short knob, secure the "sandwiched" front & rear door surrounds (FIG 15) with the short knob and tighten all three knobs (FIGs 16 & 17). All knobs on both sides of the vehicle should be secured to the roll bar.

NOTE: You will be removing the knob shown in FIG 16 to install the first bow assembly but by securing it at this step it ensures the door surrounds are secure.

This completes the installation of the door surrounds to your vehicle.

Step 5: Attach Quick Release Knobs to Over Door Bows



Locate the two quick release knobs and the Header/Deck Assembly with the over bow door attached as shown in FIG 18.

You will be installing one quick release knob into each of the over door bow ends. Line up the quick release knob in the bow end making sure the knob portion is facing inward and the slot on the Quick Release knob is vertical, up and down (FIG 19).

Step 6: Installing the Rear Bow



Using a Phillips head screw driver and the enclosed set screws, secure the Quick Release knob to the bow end through the predrilled hole in the bow (FIG's 20 & 21).

NOTE: If you cannot get the hole started in the quick release knob, you may have to drill a small pilot hole. Tighten the screw securing the Quick Release knob to the over door bow.

Repeat on the other side.

NOTICE

This next step is easier and safer if you have a friend helping you. Having a person on the other side of the vehicle to help lift and locate the front header assembly and Top Deck will be very helpful.



Step 6: Installing the Rear Bow

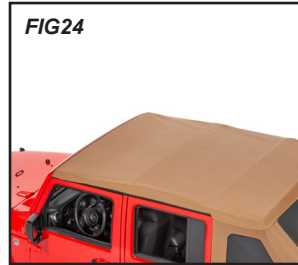
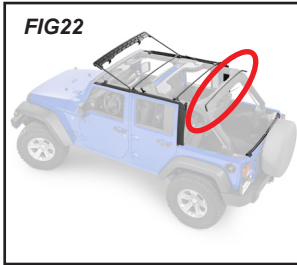

Pre-Assembly Tip: The rear bow has a flat metal plate welded to it (FIG 23). The rear bow ships from the factory wrapped onto the Soft Top Deck inside a hook and loop pocket. With the help of a friend you will need to lay the entire top deck assembly onto the vehicle with the front header resting on the windshield and the rear bow (Wrapped in the hook and loop flap) resting on the rear of the back roll bar legs (Fig's 24 & 25).



Locate the rear bow as circled in FIG 22 and mentioned above. This bow is curved at the end and has a flat bracket welded onto each end as shown in FIG 23. This bow mounts to the factory mounting point (bolt) on the rear of the roll bar under the Roll Bar padding and just behind the rear door surround (FIG 26).

Note that the next pictures do not show the fabric attached to the rear bow. This is for reference only. The rear bow should be inside the hook and loop flap during installation.



Unzip the roll bar padding towards the rear of the vehicle just past the rear door surround and right after the small Velcro flap as shown in FIG 26.

There will be a factory mounted bolt just under this flap. Using a 13mm socket and driver remove this bolt from the roll bar (FIG 27). Once removed, slip the rear bow bracket over the hole and replace the bolt (FIG 28).



Repeat this install on the other side of the vehicle so each bolt is loosely installed.

This next section is VERY important: The width of the rear roll bar legs is different on each vehicle. We have slotted the rear bow bracket to compensate for this. When tightening these two rear bolts you must make sure that the slot & bolt location is the same on each side. This will ensure the top and rear bow is centered on the vehicle.



For Example: Fig 29 shows the slot exposed on the inside of the vehicle. The rear bow is too far inboard and not centered. Fig 30 shows it centered in the slot and more importantly, centered on the roll bar. Once centered as listed above, tighten each bolt.

Re-install the roll bar padding by zipping it back up. The rear bow bracket should come right out under the Velcro flap (FIG's 31, 32 & 33).

Step 7: Installing the Second Center Bow

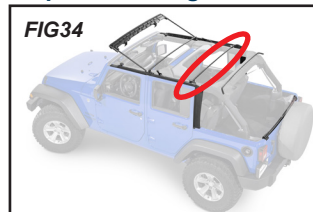

Locate the second center bow as circled in FIG 34. This bow has a small flat bracket welded onto each end as shown in FIG 35. This bow mounts to the rear Door Surround knob location.

Remove the rear door surround Knobs from each side of the vehicle and place the second center bow bracket hole over the door surround hole (FIG 36). Make sure the bow is rear of the Door Surround Knob. Line up one side and place the long door surround knob into the hole (Fig 37) securing the center bow (Do not tighten yet).



Go to the opposite side of the vehicle and line up the holes and place the knob in the hole. Now tighten each knob securing the bow to the door surround.



Step 8: Installing the First Center Bow



The first center bow has been permanently installed to the deck assembly with screws. Fold back the Windshield header as shown in FIG 38 which will expose the bow mount brackets installed on the first bow. The bow ends on the first bow have a multi piece bracket welded to the end of the bow (FIG39). This center bow attaches to the vehicle using the short door surround knob installed in step 4 above, located in between the front and rear door surround (FIG 40). Remove these door surround Knobs from each side of the vehicle and place the center bow bracket hole over the door surround hole. The center bow should be towards the rear of the vehicle. Line up one side and place the short door surround knob into the hole securing the center bow (Do not tighten yet) (FIG41).

Go to the opposite side of the vehicle and line up the holes and place the knob in the hole. Now tighten each knob securing the bow to the door surround (FIG 42). See note below.

NOTE: The oval cutout on the bow bracket must fit into the oval on the door surround. It should be flush when installed and there should be very little if any movement of this bracket once secured with the door surround knobs.

Step 9: Installing the Top Deck and Front Windshield Header Assembly



With the first bow installed to the vehicle and the front windshield header folded back (FIG 43), locate the Quick Release knobs on the ends of the over door bows and slip the knob into the hole in the first bow mount (FIG 44) by pulling the knob out and then releasing. Repeat on the other side. This will secure the back of the header assembly to the vehicle (FIG45).

Step 10: Installing the Top Deck



With the front header folded back towards the rear of the vehicle and on top of the second bow (FIG 46), locate the rear spring straps that have a buckle and D-Ring attached to it. The end of this strap has a loop sewn into it. Detach the "looped end" portion of the strap from the buckle.

This strap will wrap under the rear seat belt post and back through the loop (FIG's 47 & 48) and then from the inside and around the roll bar back up towards the rear bow leg (FIG 49).

As shown in FIG 50, make sure the strap comes from the inside of the vehicle out and up towards the front of the vehicle and over the Rear bow leg. Re-attach the strap end to the buckle/D-Ring assembly.





Step 10: Installing the Top Deck Continued

Thread the end of the tensioner through the flap/tube sewn into the top deck and attach the tensioner to the spring assembly that is hanging out of the top deck (FIG 51). Repeat this procedure on the other side of the vehicle.

Go to the front of the vehicle and fold the front header down to the windshield but do not latch. Loosely tighten the rear straps attached to the spring assembly, starting on one side and alternating to the other so the top deck is centered.

Make sure the tube/strap is on the outside of the Door Surround and the strap is located over the rear bow leg (FIG 52).

When loosely tightening, the cable that is attached to the spring will fit over the rear bow and under the pre-installed screw on the door surround (FIGS 53 & 54). **SEE Note Below!**

NOTE: Do not fully tighten these straps until advised to do so in step 11 when the front header is closed and latched on the windshield. If these straps are fully tightened before you fold down the front header you will damage the top!

Step 11: Installing the Side and Rear Windows



To ensure the top is centered on the vehicle you need to attach the two quarter windows and the rear window to the top deck and then to each other before securing it to the vehicle body.

Pro-Install TIP: To make this as easy as possible, the front windshield header should be released(not clamped down) and keep the rear corner straps installed in step 10 loosened.

This will allow you to line up all window zippers and attachments. The rear corner straps and header will need to be re-tightened/clamped before using the top.

NOTE: Do not fully tighten these straps until advised to do so in step 11 when the front header is closed and latched on the windshield. If these straps are fully tightened before you fold down the front header you will damage the top!

Locate the drivers rear quarter window. Line up and slide the rear quarter window into the "C" Channel as shown in FIG's 55 & 56 . Repeat this on the passenger side of the vehicle. Locate the rear window and line up and slide the rear window into the "P" Channel located at the top of the rear portion of the top deck and slide it across (FIGs 57 & 58).

With the windows and the upper portion of the rear window secured to the top deck, and the driver's side rear zipper on the Quarter window pre-attached to the zipper on the rear window, zip the zipper down a few inches (FIG 59).

Repeat this on the passenger side of the rear window. You may have to lift the quarter window up to secure this second zipper a few inches.

Once both side zippers are attached, zip the rear window zippers down about a quarter of the way (FIG 60). You will close these zippers completely at the end of the install. Go to the front of the vehicle and latch the front header so it is secured to the windshield with the two front latches. This should be very easy.

If there is tension, loosen the Side D-ring straps!

Proceed to next page





Step 11: Installing the Side and Rear Windows-Continued

Go inside to the back seat of the vehicle and locate the second center bow hook and loop flap sewn into the top deck. Wrap this flap around the second center bow securing the top deck to the bow (FIG61).

With the front header latched and the second bow flap secured, Loosen the corner hook and loop and locate the D-Ring corner straps (FIG's 62 & 63). Tighten the driver's side D- Ring strap then passenger side alternating each side to make sure the top is tightened the same on both sides of the vehicle (FIG 64). Make sure the top is centered on the vehicle while you are tightening.

NOTE: The cable/pocket should be on the outside of the door surround and the strap should be over the rear bow leg (FIG 63). Also make sure the cable located after the spring attachment is secured under the screw on the door surround (see FIG's 53 & 54)

NOTICE

When removing the quarter and rear windows from the Top deck be sure to slide them out completely before pulling down. Disengage the side hook and loop before sliding the windows out. DO NOT "Peel" the windows out! Failure to completely disengage the windows from the "C" Channel will damage the Top and quarter window!

Step 12: Securing the Side and Rear Windows to the Vehicle



As shown in FIG's 65 & 66, roll the vertical plastic strip into the door surround slot securing it to the door surround. Next, starting at the driver's side front, attach the side belt rail into the vehicle body by "rolling" the plastic into the slot (FIG's 67 & 68).



Once secure move to the rear driver's side corner and "roll" the plastic into the Jeep body corner belt rail while pulling back towards the rear of the vehicle as shown in FIG 69. Repeat the quarter window and corner install on the passenger side of the vehicle.

You may have to pull the corners around towards the front or back of the vehicle to center the top on the vehicle and to pull the zippers closer.

Step 13: Securing the tailgate bar & rear window to the vehicle



Open the tailgate. Take the factory tailgate bar and orient the "C"-Channel with the round seal facing down. Slide the "C" Channel onto the rear window retainer as shown in FIG's 70 & 71.

Clip the rear Tailgate retaining brackets to the body tub just outside the tailgate opening. Roll the tailgate bar into the mounts with the outside of the fabric facing towards the rear rear of the Vehicle (FIG's 72 & 73).



Step 14: Securing the Hook and Loop Fasteners



FIG 74



FIG 75



FIG 76



FIG 77



FIG 78

Once the Tailgate bar is secure, lower zippers on both sides of the rear curtain and then secure the rear corner flaps as shown in FIG 74.

Work your way around the outside of the vehicle and secure all Hook and loop sealing up the zippers above the windows and down the rear window. (Figs 75, 76, 77 & 78).

WARNING

Make sure the hook and loop fastener are tightly secured to the second and rear bow before the front sun roof is folded back. Both rear corner straps must also be secure when the top is folded back. Make sure these flaps are secure before driving. These safety measures are designed to secure the top deck to the vehicle (along with the permanently installed first bow) and if not adhered to can cause injury, death and a serious accident. Always wear your seat belts when using this product!

Care and Maintenance of your MasterTop Soft Top:

Your MasterTop Accessories are made of the finest materials available but to keep it looking new and for the maximum possible wear, it will need periodic cleaning and basic maintenance. The main threat to your Product is pollutants, dirt and grime. By keeping your products clean you will prolong the life of your accessories.

We recommend the following to keep your cover like new:

Washing:

The curtain fabric should be washed often using a mild soap, warm water and a soft bristle brush. You can also use special soft top cleaners available on our Distributors websites. Make sure that after cleaning you rinse with clear water to remove all traces of soap to avoid residue. Air Dry. Do not put in dryer.

Water/Fabric:

In the event of seeping through the seams, 3M Scotchgard® may be applied on the inside of the seams to stop the seeping. Rips in the fabric may be repaired with Bondex® iron on patches. Iron the patches to the Inside of the top, carefully following the Bondex® instructions.

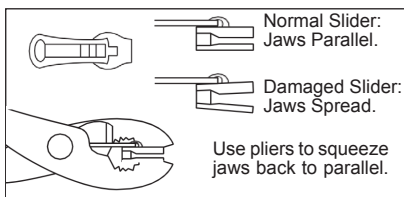

Zippers:

Keeping the zipper cleaned and lubricated with a silicone lubricant (available online) will help prevent damage and keep the zippers in a smooth working condition. If zipper opens behind the slider, the slider may have been spread apart. This problem can usually be fixed by using an ordinary pair of pliers to bring the sides back into parallel. Return slider to the end of the zipper in the normal Open position. Squeeze lightly at first and test zipper. If the zipper continues to remain open squeeze more firmly with pliers and try the zipper again. Repeat procedure until your zipper operates correctly.





Limited 3 Year Warranty

Your MasterTop® accessory is covered by the following Limited Warranty provided exclusively by MasterTop, Inc., 420 J Corporate Circle, Golden, CO 80401.

This Limited Warranty is the only warranty made in connection with your purchase. MasterTop neither assumes nor authorizes any vendor, retailer or other person or entity to assume for it any other obligation or liability in connection with this product or Limited Warranty. This Limited Warranty does not apply and is not cumulative to any accessory or part distributed by any MasterTop distributor for which the Manufacturer provides a separate written warranty.

What is Covered: Subject to the terms, exclusions and limitations herein and with respect only to MasterTop branded accessories first sold in the United States, MasterTop warrants to the initial retail purchaser only that your MasterTop accessory shall be free of defects in material and workmanship; **for a period of 3 years from date of initial retail sale.**

All other warranties are hereby disclaimed, except to the extent prohibited by applicable law in which case any implied warranty of merchantability or fitness for a particular purpose on this product **is limited to 3 years from date of initial retail sale.** MasterTop reserves the rights to: (a.) require invoice or other proof your product is within the terms of this Limited Warranty as a condition of warranty service and, (b.) make future revisions to this product and Limited Warranty without prior notice or obligation to upgrade your product.

What is Not Covered: Your MasterTop Limited Warranty does not cover products or parts MasterTop determines to have been damaged by or subjected to: (a.) installation damage, alteration, modification, failure to maintain or attempted repair or service by anyone not authorized by MasterTop, (b.) normal wear and tear, cosmetic damage or damage from water immersion, (c.) Acts of God, accidents, misuse, negligence, inadequate mounting or impact with vehicle(s), obstacles or other aspects of the environment, (d.) theft, vandalism or other intentional damage, (e.) fleet, rental or commercial use, (f.) use in competition or racing.

Remedy Limited to Repair/Replacement: The exclusive remedy provided hereunder shall, upon MasterTop inspection and at MasterTop's option, be either repair or replacement of product or parts (new or refurbished) covered under this Limited Warranty. Customers requesting warranty consideration on MasterTop Products should first contact MasterTop to obtain a RGA number (720-575-5440). All labor, removal, shipping and installation costs are customer's responsibility.

Other Limitations - Exclusion of Damages

- Your Rights Under State Law:

In consideration of the purchase price paid, neither MasterTop nor any independent MasterTop distributor /licensee are responsible for any time loss, rental costs, or for any incidental, consequential, punitive or other damages you may have or incur in connection with any part or product purchased. Your exclusive remedy hereunder for covered parts is repair/replacement as described above.

This Limited Warranty gives you specific rights. You may also have other rights that vary from state to state. For example, some states do not allow limitations of how long an implied warranty lasts and/or do not allow the exclusion or limitation of incidental or consequential damages, so the limitations and exclusions herein may not apply to you.

©MasterTop, Inc. 2021. All Rights Reserved. The term MasterTop® is a Registered Trademark of MasterTop Incorporated, Registered in U.S. Patent and Trademark Office.

www.MasterTop.com

Part #941047.01 Version 11.8.21

