



# INSTALLATION INSTRUCTIONS

## 2009-2014 Ford F-150 Console Insert #334

Fits Trucks with Full Console and Column Shift

Please read and fill out the enclosed warranty registration card or register online at <https://tuffyparts.com/warranty-registration/> to activate your warranty.

Call (800) 348-8339 for Technical Support

### PARTS CHECKLIST

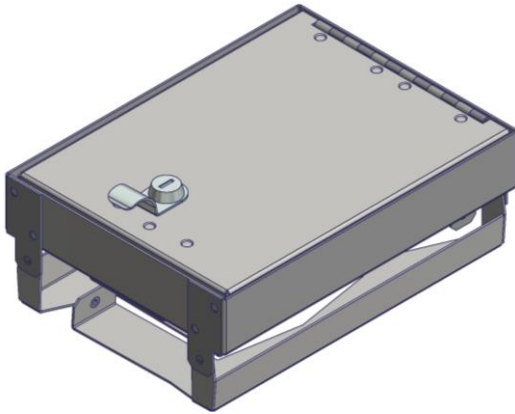

Console Insert #334

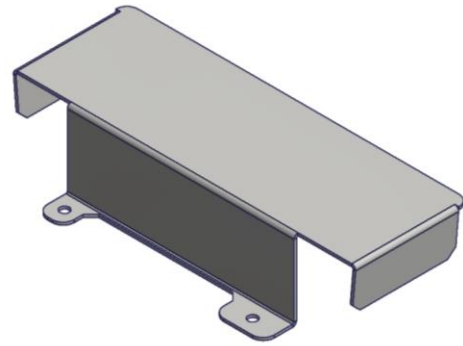

#6 (1) Front Block Plate

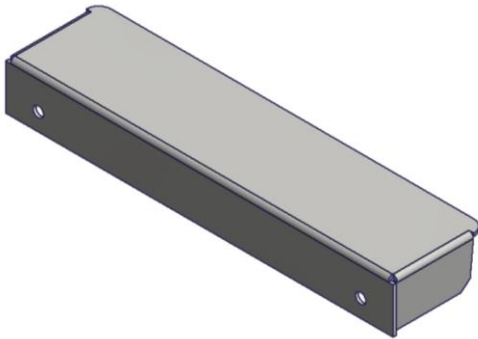

#7 (1) Rear Block Plate

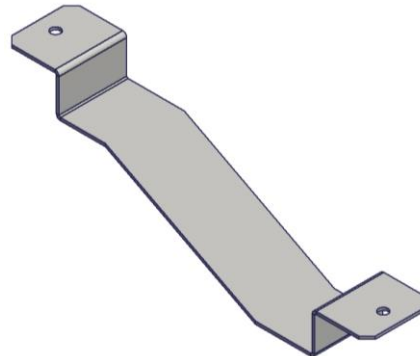

#8 (2) Bottom Plate

### SHIPPING PACKAGE CONTENTS

(Included In Key Bag)



#12.1 (4)  
#10-32 x 3/16" Screw

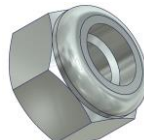

#12.2.1 (1)  
1/4"-20 Nylock Nut



#12.2.2 (1)  
1/4"-20x5/8" Cap Screw

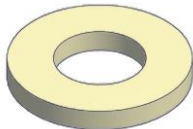

#12.2.3 (2)  
1/4" Nylon Washer



#12.3 (4)  
#10-32 x 1/2" Screw



#12.4 (4)  
#10-32 Nylock Nut

#### Tools needed for standard installation:

•Phillips Head Screwdriver

•3/8" Wrench/Socket

•5/32" Hex Wrench

•7/16" End Wrench

**PLEASE READ ALL INSTRUCTIONS THOROUGHLY BEFORE STARTING INSTALLATION.**

1. Remove all contents from the shipping box and confirm that you have all of the components listed on Page 1.
2. Remove the contents of the factory console, including the bottom mat, if equipped.
3. Invert the #334 Console Insert so it rests on its lid, expand the legs and attach the #7 Rear Block Plate to the main body as shown in Figure 1, using (2) #12.3 Screws, and (2) #12.4 Nylock nuts.

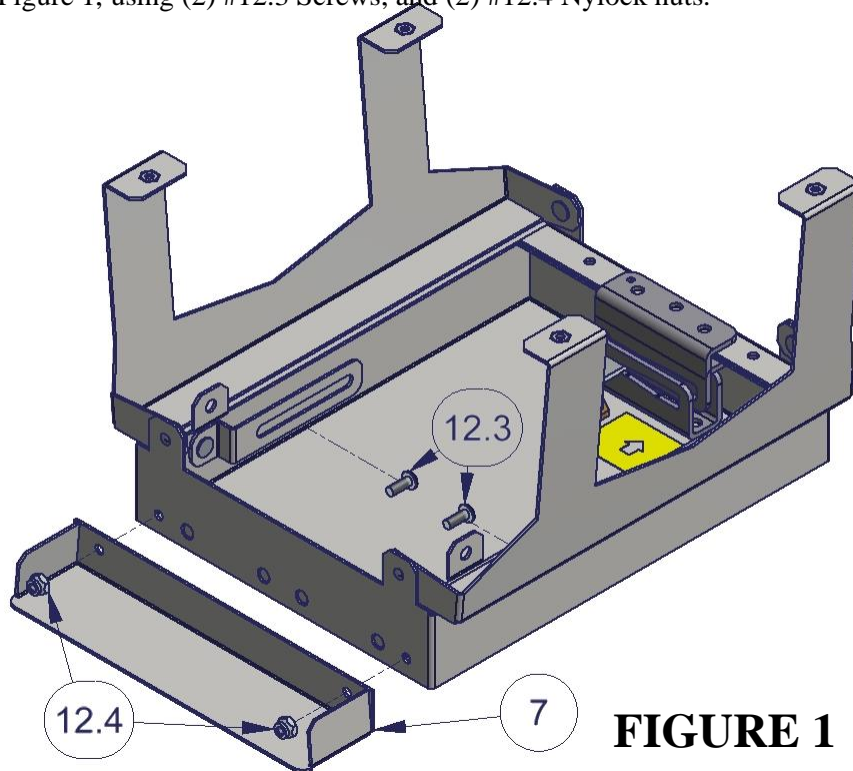

**FIGURE 1**

4. Return the Insert to the upright position, open the lid, and attach the #6 Front Block Plate as shown in Figure 2, using (2) #12.3 Screws, and (2) #12.4 Nylock nuts.

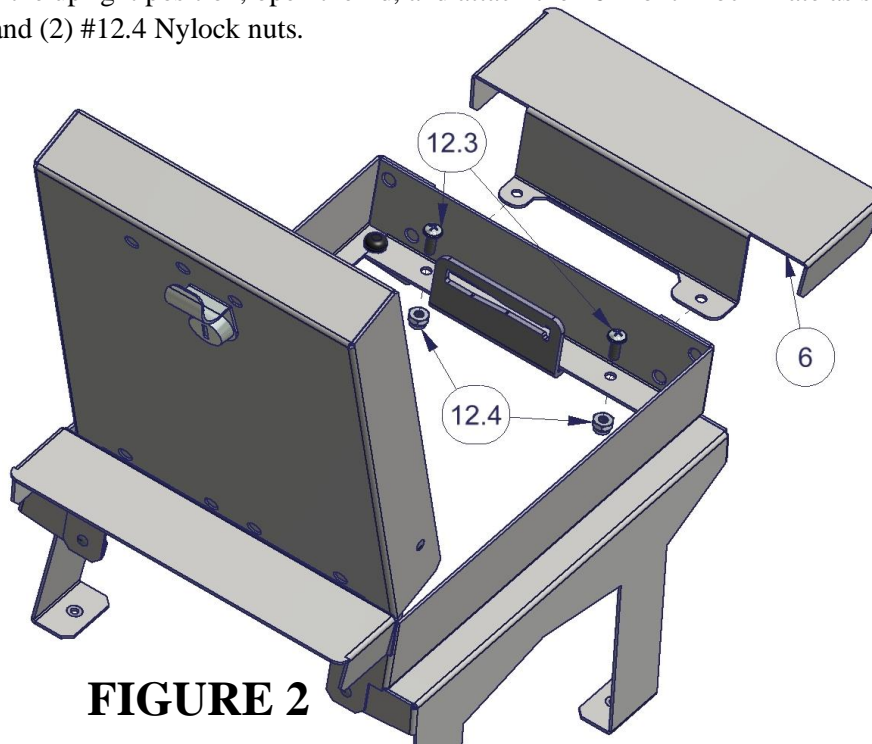

**FIGURE 2**

5. Open the factory console lid, fold up the Console Insert legs (being careful not to bend the friction bracket attached to lid) and lower the insert into the console, by angling the front (lock end) of Insert into console opening first. Leaving the Insert folded on the bottom of the console.
6. Raise the Insert into its final position, by opening the lid, expanding the legs, and placing the bases of the legs on the raised ribs in the bottom of the console.
7. Attach the #8 Bottom Plates to the assembly using (4) #12.1 Screws, as shown in Figure 3.

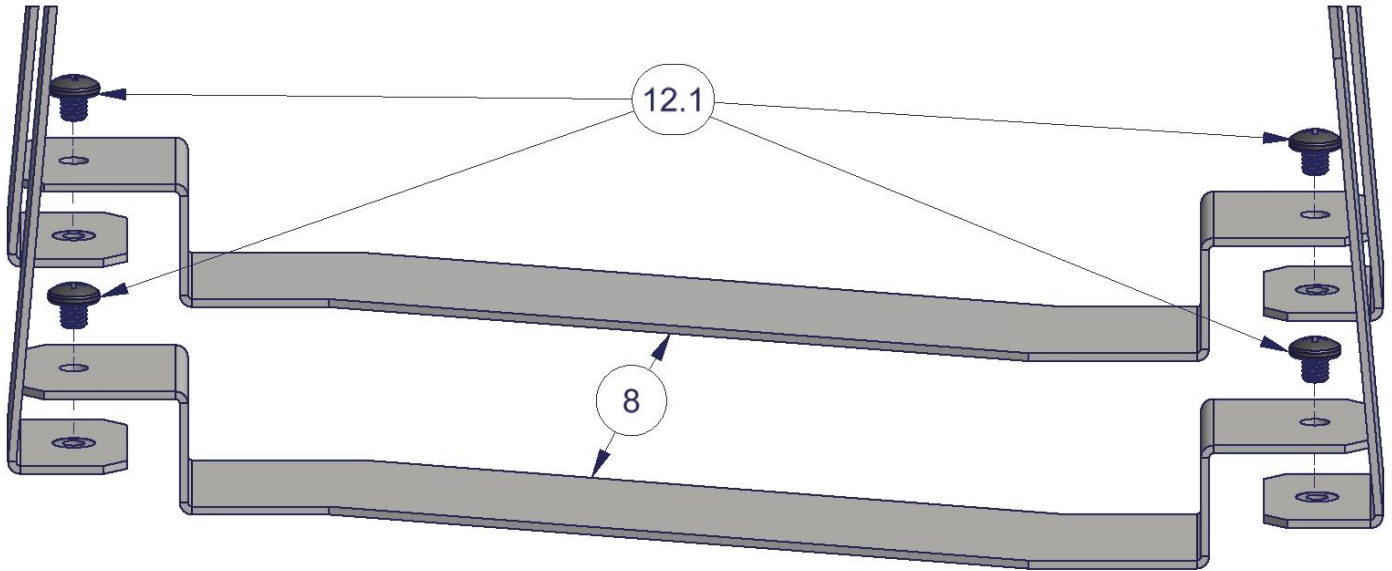
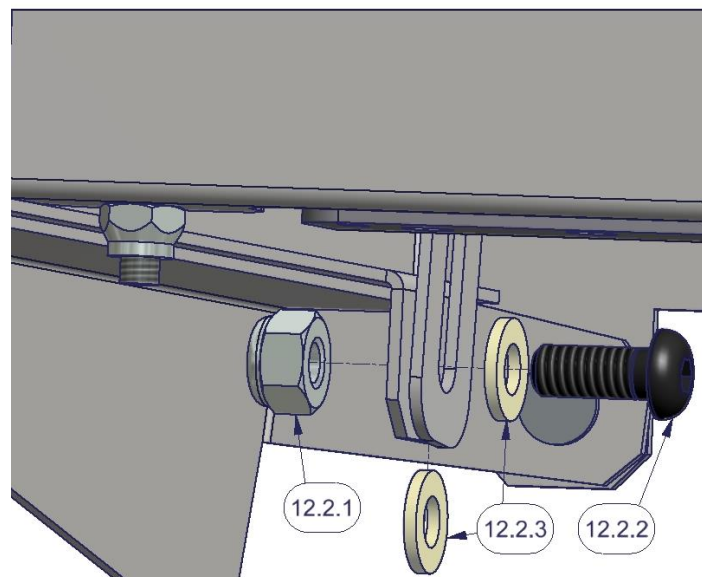

**FIGURE 3**

8. Assemble the lid support hardware, as shown in Figure 4. Tighten the hardware in small increments so that the lid remains supported as you require (usually self-supporting at a 45 degree lid angle).

NOTE: Second nylon washer (#12.2.3 shown below assembly in Figure 4) slips between moving slotted part, and stationary body.

NOTE: Over time the friction that holds the lid in the open position may be reduced as a result of use, and it may become necessary to tighten the assembly. Tighten in small increments and test by opening/closing the lid.



**FIGURE 4**

9. Replace the contents of the console starting with the bottom mat (if equipped).